

# Pressure Relief Valve DHV 712



## Advantages

- for high pressure constancy
- reliable reduction of pressure peaks and pulsations
- pressure settings at any time, also during operation
- hermetically sealed by diaphragm
- in off-position 100% free of back pressure

## Application

- chemical plants
- water treatment
- electroplating

## Utilisation

- for maintaining constant counter pressures being caused by operation or system
- for reducing pressure peaks
- for preventing any pressure pulsations

## Flow media

- Technically clean neutral and aggressive media provided that the components coming into contact with the medium are resistant at the operating temperature according to the ASV resistance guide.

## Size

- DN 65 - DN 100
- DN 10 - DN 50 see DHV 712-R (print 330156)

## Media temperature

- see pressure/temperature diagram

## Nominal pressure (H<sub>2</sub>O, 20°C)

- PN 10

## Operating pressure

- see pressure/temperature diagram

## Set range

- |               |              |
|---------------|--------------|
| • DN 65 - 80  | 0.5 - 10 bar |
| • DN 65 - 100 | 0.3 - 4 bar  |
| • DN 100      | 0.5 - 6 bar  |

## Working pressure

- see characteristic curves

## Opening pressure

- approx. 0.3 - 0.5 bar

## Hysteresis

- difference between opening and closing pressure approx. 1 bar

## Valve body, piston, separation disc

- PVC-U (polyvinyl chloride)
- PP (polypropylene)
- PVDF (polyvinylidene fluoride)

## Valve bonnet

- PP, glass fibre reinforced

## Diaphragm

- PTFE-vulcanised EPDM-diaphragm on medium side

## Sealing

- EPDM
- FPM

## Connection screws

- stainless steel 1.4301 (V2A)

## Connection

- spigot ends for solvent welding DIN/ISO (PVC-U)
- spigot ends for fusion welding DIN/ISO (PP, PVDF)

## On request with

- backing flanges acc. to DIN 2501 (PN 10/16)

## Mounting

- variable

## Flow direction

- always in the direction of the arrow

## Colour

- |      |        |                          |
|------|--------|--------------------------|
| body | PVC-U: | grey, RAL 7011           |
|      | PP:    | grey, RAL 7032           |
|      | PVDF:  | opaque (yellowish-white) |

## Pressure Relief Valve DHV 712

### Pressure/temperature diagram

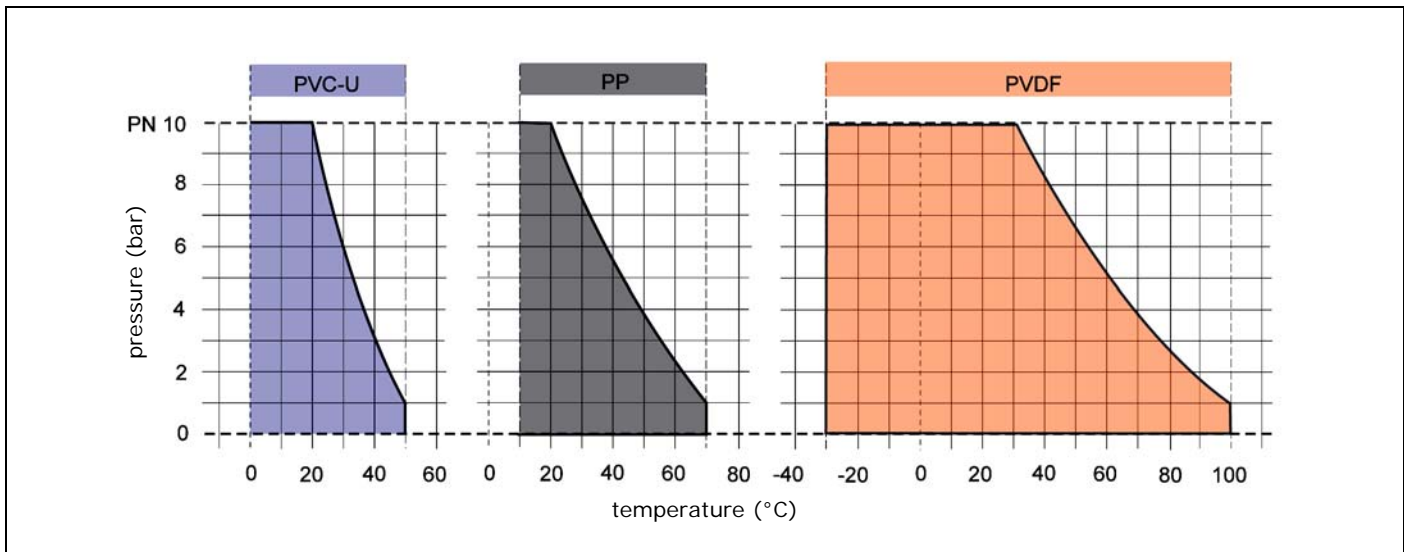

The pressure/temperature limits are applicable for the stated nominal pressures and a computed operating life factor of 25 years.

The values are a guide for harmless media (DIN 2403), to which the material of the valve is resistant.

For other media see the ASV resistance guide.

The durability of wear and tear parts depends on the operating conditions of the application.

For temperatures below 0°C (PP < +10°C) please specify the precise operating conditions of the application.

### Sectional drawing type DHV 712

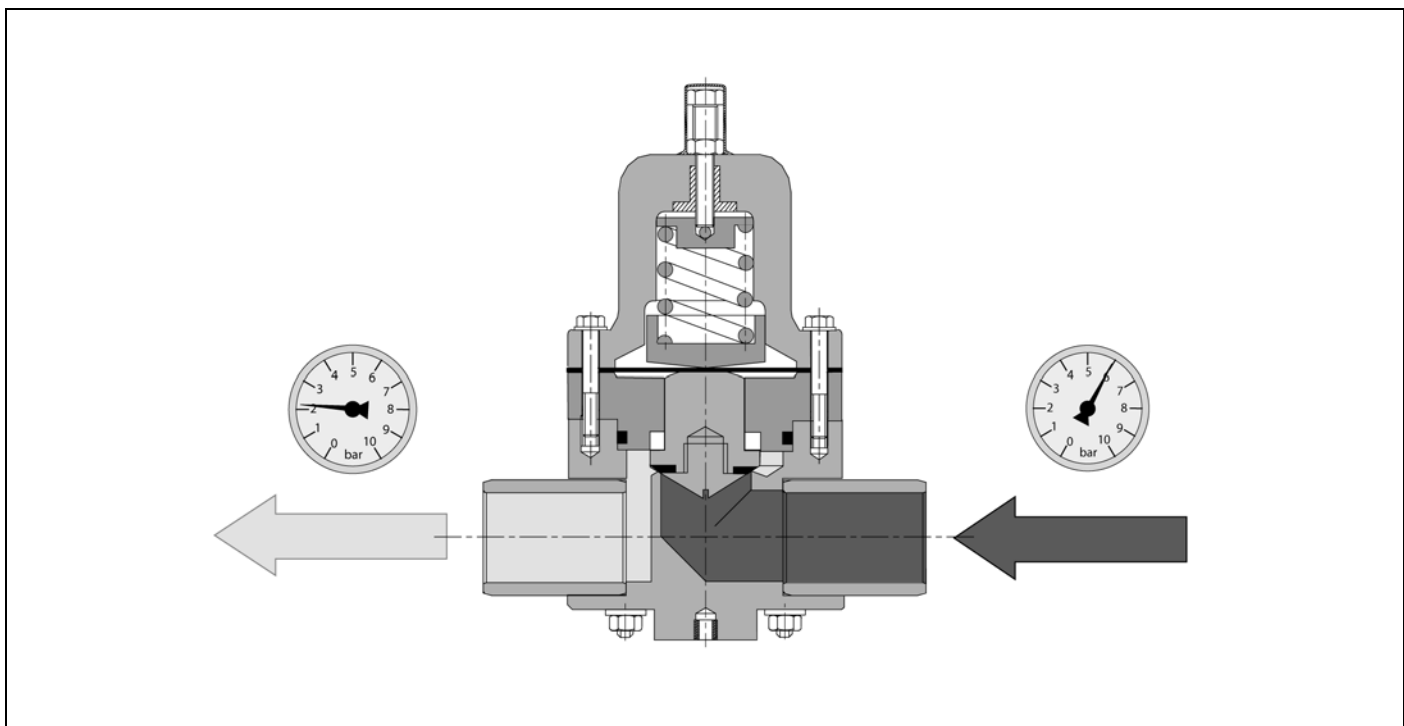

# Pressure Relief Valve DHV 712

## Valve function and design

If the operating or primary pressure rises above a certain preset pressure value, the pressurized valve piston is lifted against the spring force. The valve opens and a pressure relief on the secondary side takes place.

It closes as soon as the pressure at the diaphragm drops below preset pressure.

A constructional damping at the piston prevents hunting.

The diaphragm separates the fluids in the valve body from the atmosphere.

## Valve settings and adjustment

A presetting or readjustment of the required or allowable operating pressure can be arranged by the adjustment screw (13). After having removed the protection cap (9) and loosened the counter nut (14) the pressure setting can be made with the help of a pressure control device (e.g. ASV diaphragm pressure gauge guard type MDM 902). The adjustment screw (13) is locked with the counter nut (14) and can be leaded upon request.

## Pressure relief valve with pressure gauge

For neutral media the valve can be equipped by the manufacturer with a gauge.

For other media check the resistance of the gauge material.

### NOTE

If the valve is equipped with a pressure gauge, the pressure gauge may be tightened with max. 3 Nm only. ✓

## Operating instructions

### ATTENTION

Safe operation of the valve can only be ensured if it is properly installed, operated, serviced or repaired by qualified personnel according to its intended use while observing the accident prevention regulations, safety regulations, relevant standards and technical regulations or data sheets such as DIN, DIN EN, DIN ISO and DVS\* for example. ✓

\*DVS = German Welding Society

The intended use includes adhering to the specified limit values for pressure and temperature as well as checking the chemical resistance with regard to the operating conditions.

For this purpose, ensure that all components coming into contact with the media are **»resistant«** in accordance with the ASV resistance guide.

The owner/user must inform the authorized qualified personnel instructed to perform the assembly, inspection and/or maintenance work of any potential danger emanating from the machine line/medium, and ensure that suitable safety measures are observed. This also includes the consideration of local regulations and laws of the territories of use.

If no mounting and instruction manual is available to the authorized qualified personnel, please request a manual prior to installation, maintenance or repair.

Non-observance of the specified instructions and safety

regulations may cause damage to health and/or damage to assets.

## Tightening torque

### NOTE

In the event of diaphragm settling and/or temperature fluctuations, it is necessary to check the tightening torque of the housing screws at certain intervals. ✓

Following tightening torque must be observed:

tightening torque			
d (mm)	75	90	110
MD (Nm)	20	20	20

tightening torque for lubricated screws

### NOTE

Do not allow elastomer components, especially the EPDM sealing elements, to come into contact with synthetic or mineral oils, grease or cleaning agents. Danger of swelling. Only appropriate grease should be used such as silicone grease. ✓

## We recommend

- installing of filter or strainer (see print 330034) directly before the valve for avoiding impurities, e.g. at valve seat.

## Pressure Relief Valve DHV 712

### Dimension

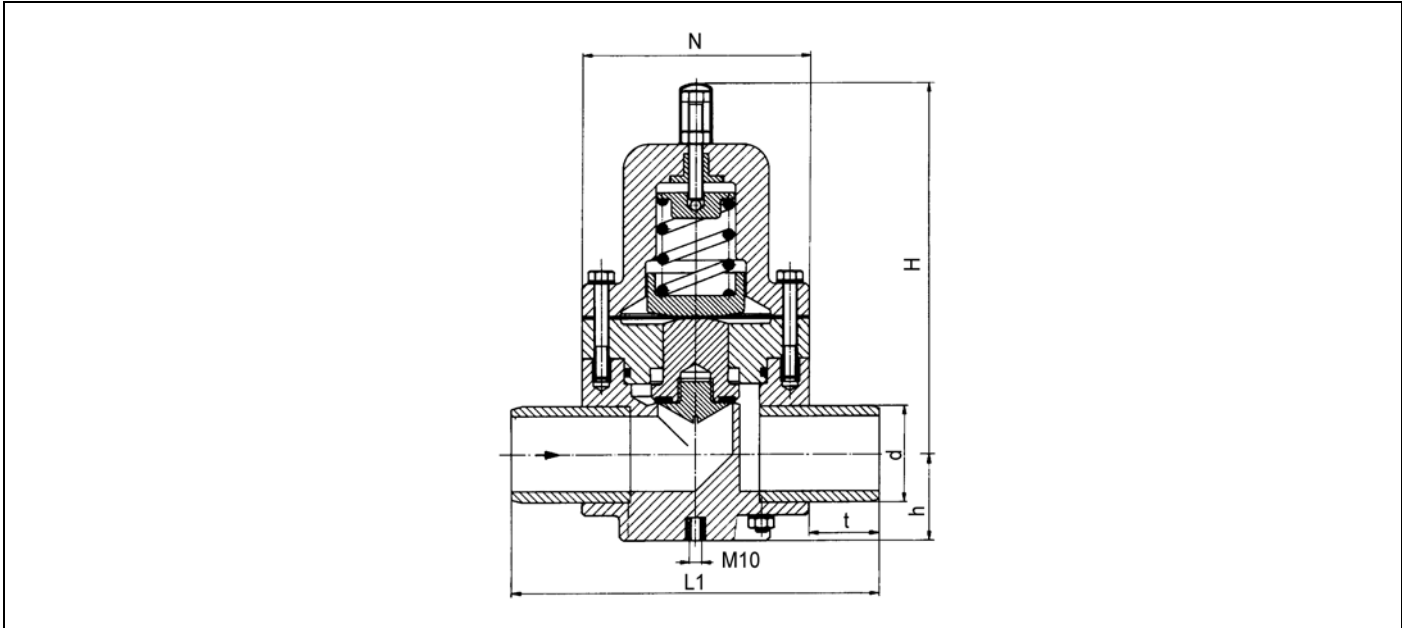

dimension	d (mm)	75	90	110
DN (mm)		65	80	100
DN (inch)		2 1/2	3	4
H		282	310	360
h		68	75	95
L1		284	360	420
N		175	200	250
t		54	80	85

### Weight

weight (kg)	d (mm)	75	90	110
PVC-U		9,5	12,0	15,0
PP		7,0	10,8	12,0
PVDF		11,2	14,0	17,0

### Ident number

ident number	d (mm)	75	75	90	90	110	110
DN (mm)		65	65	80	80	100	100
DN (inch)		2 1/2	2 1/2	3	3	4	4
PN (bar)		10	10	10	10	6	6
<b>set range (bar)</b>		<b>0,3 - 4</b>	<b>0,5 - 10</b>	<b>0,3 - 4</b>	<b>0,5 - 10</b>	<b>0,3 - 4</b>	<b>0,5 - 6</b>
<b>PVC-U</b>	EPDM	110545	110060	110548	110063	112926	111856
	FPM	112920	112911	112923	112914	112929	112932
<b>PP</b>	EPDM	110546	110061	110549	110064	112927	111857
	FPM	112921	112912	112924	112915	112930	112933
<b>PVDF</b>	EPDM	-	-	-	-	-	-
	FPM	112922	112913	112925	112916	112931	112934

# Pressure Relief Valve DHV 712

## Spare parts list and designation

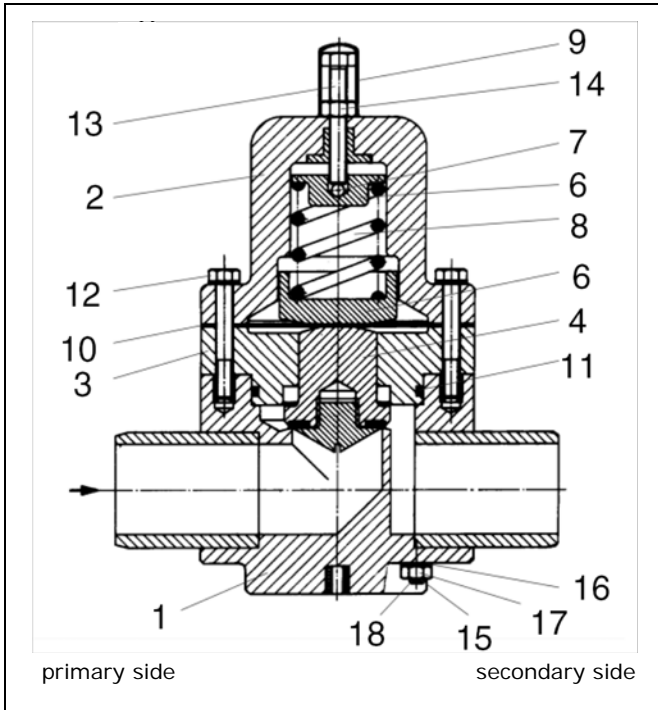

item	designation	qty.
1	body	1
2	bonnet	1
3	separation disc	1
4 <sup>1)</sup>	piston complete	1
5	spring plate	1
6	pressure plate	1
7	steel ball	1
8	pressure spring	1
9	cap	1
10 <sup>1)</sup>	diaphragm	1
11 <sup>1)</sup>	O-ring	1
12	screw	2
13	adjustment screw	1
14	counter nut	1
15	hexagonal screw	8
16	washer	8
17	hexagonal nut	8
18	protection cap	18

1) recommended spare parts  
 Materials according to ident number.

## Pressure Relief Valve DHV 712

### Characteristic curves DN 65

#### 0.3 - 4 bar

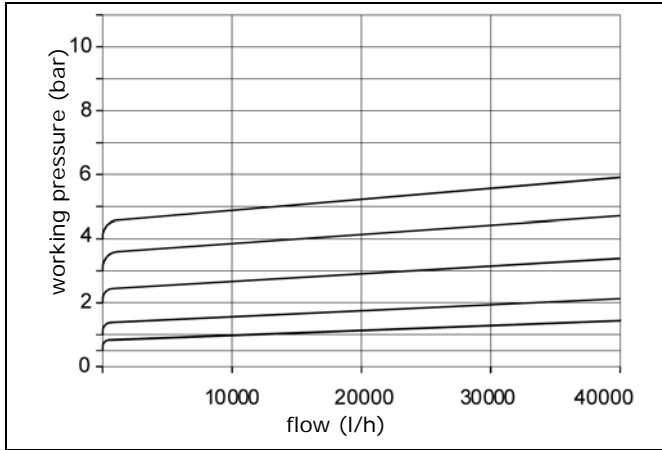

#### 0.5 - 10 bar

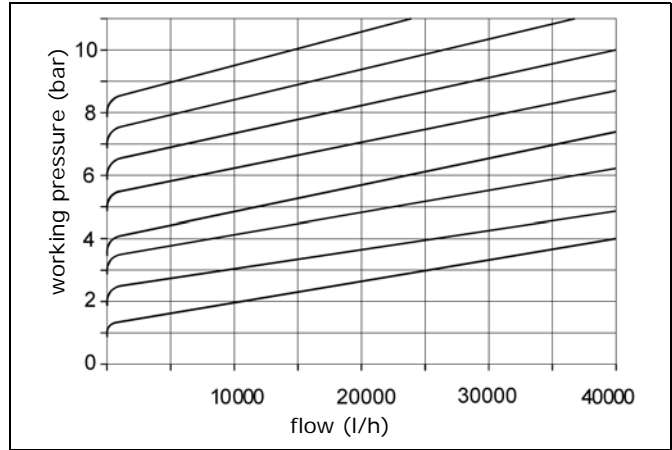

### Characteristic curves DN 80

#### 0.3 - 4 bar

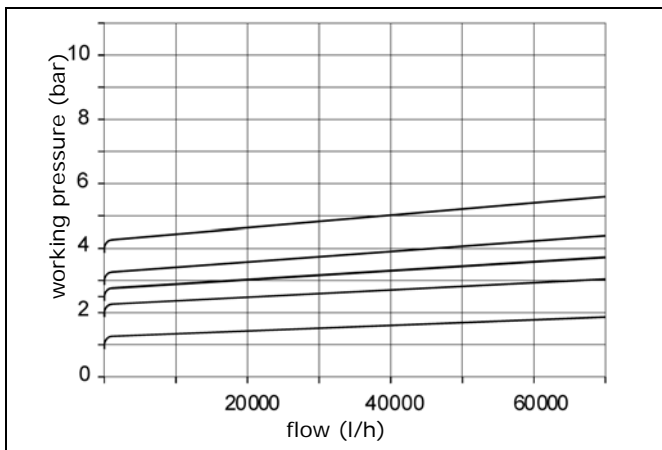

#### 0.5 - 10 bar

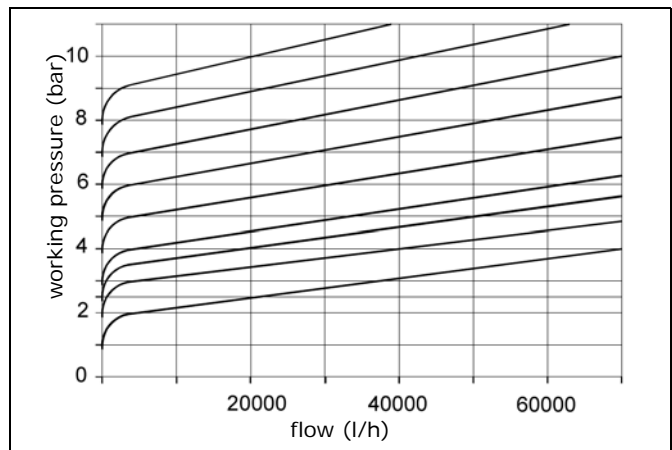

### Characteristic curves DN 100

#### 0.3 - 4 bar

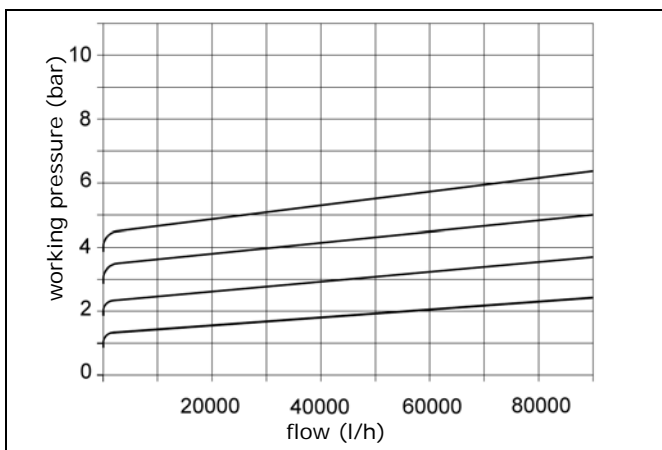

#### 0.5 - 6 bar

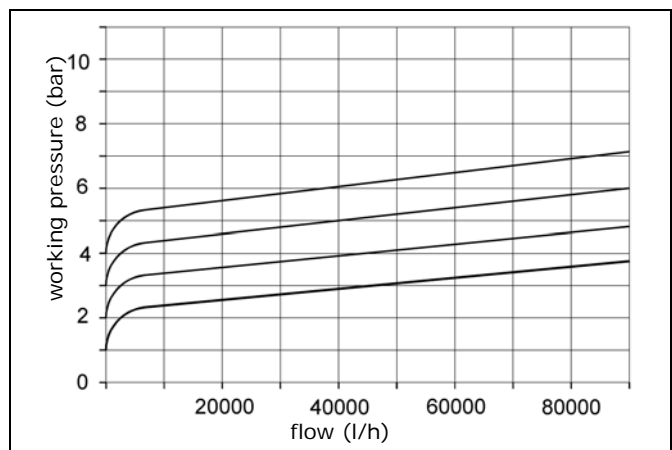



# Pressure Relief Valve DHV 712

## Characteristic curves

### Example:

#### DN 100 / 0.3 - 4 bar

The valve is closed at 2 bar.

At a pressure increase of 1 bar the flow of about 45000 l/h is reached.

## Failures, possible causes and repair

Failure	Cause	Repair
Valve is leaking at diaphragm.	Diaphragm clamping force too low.	Tighten screws (12).
Pressure drops below set pressure.	Valve seat/seals are defective.	Check piston and seat seal and replace if necessary.
	Diaphragm (10) is leaking.	Replace diaphragm.
Pressure rises above set value.	Valve mounted in wrong direction.	Turn valve in direction of arrow.
Valve is leaking at adjustment screw.	Diaphragm damaged.	Replace diaphragm.

Subject to technical modifications

